



2633 Upper James St, Mount Hope, Ontario, L0R 1W0
+1.905.679.2122 EX2 / info@rmcontario.com
A division of Canadian Mini Indy Inc.

2024 RMC Ontario Championship Supplementary Regulations

June 5th, 2024

Table of Contents

1.	<i>The RMC Ontario Championship</i>	3
2.	<i>Sanctioning</i>	3
3.	<i>Series Inquiries</i>	3
4.	<i>2024 Series Schedule</i>	3
5.	<i>Driver, Team and Parental Sportsmanship Theme</i>	3
6.	<i>Event and Championship Awards</i>	3
7.	<i>Points Chart</i>	4
8.	<i>Event Officials</i>	5
9.	<i>Regulations and Precedence of Regulations</i>	5
10.	<i>Amendment to Regulations</i>	5
11.	<i>Wet Tires</i>	6
12.	<i>Race Tires</i>	6
13.	<i>Fuel Specification:</i>	6
14.	<i>Oil Specification</i>	6
15.	<i>Eligible Entries and License Requirements</i>	6
16.	<i>Competition Numbers</i>	7
17.	<i>Event Schedule</i>	7
18.	<i>Additional or Team Paddock Spaces</i>	7
19.	<i>Restricted Areas</i>	7
20.	<i>Number of Karts on the Racetrack</i>	7
21.	<i>Eligibility to Race in a Pre-Final and Final Race</i>	7
22.	<i>Qualifying Procedures</i>	8
23.	<i>Transponders</i>	8
24.	<i>Marking of Engine and Tires</i>	8
25.	<i>Re-starting Karts</i>	8
26.	<i>Race Starts</i>	8
27.	<i>Procedure at the End of a Qualifying Session or Race</i>	9
28.	<i>Procedure at the End of Finals</i>	9
29.	<i>Photography, Audio and Video Recording in Technical Inspection Areas</i>	9
30.	<i>Official Notice Board</i>	9
31.	<i>Podium Ceremony</i>	9

1. The RMC Ontario Championship

RMC Ontario events are organized by the Canadian Mini Indy with exception of Round 4. Round 4 is organized and managed by Ron Fellows Karting Group. The “Motomaster Canadian Karting Championships” event rules and regulations will be utilizing the complete event rules set making this document null and void for round 4 event.

The RMC Ontario Championship will count the best 4 out of 5 points finishes (1 Drop).

2. Sanctioning

RMC Ontario is recognized as a National Series by Sports Development Group/Groupe de Development Sportif (GDS), the National Sporting Authority (ASN) in Canada.

3. Series Inquiries

Canadian Mini Indy Inc (Promoter)
2633 Upper James St, Mount Hope, Ontario
info@rmcontario.com

4. 2024 Series Schedule

The series is a four event Championship made up of five races.

ROUND 1	July 14	Hamilton Karting Complex, Hamilton, Ontario - Clockwise	Race 1
ROUND 2	August 10 - 11	Hamilton Karting Complex, Hamilton, Ontario - Counterclockwise	Races 2 & 3
ROUND 3	August 15 - 18	Hamilton Karting Complex, Hamilton, Ontario – Counterclockwise (DOUBLE POINTS EVENT)	Race 4
ROUND 4	September 7	Hamilton Karting Complex, Hamilton, Ontario – Clockwise (Night Race)	Race 5

5. Driver, Team and Parental Sportsmanship Theme

All participants, including entrants, drivers, crew members and parents/guardians shall conduct themselves according to the highest standards of behavior and sportsmanship, particularly in relations to other competitors, officials, Sponsors and their products, and in a manner that shall not be prejudicial to the reputation of the RMC Ontario Championship, Canadian Mini Indy, promoters, sponsors, organizers, or to kart sport in general.

Sportsmanship means any person’s conduct and behavior while participating in a sport. Examples are fairness, respect for one’s opponent, and graciousness in winning or losing.

Any abuse of officials or other participants will not be tolerated. Entrants, drivers, and parents/guardians are always responsible for the conduct of their driver, crewmembers, and guests. Any violation of this regulation is directly chargeable to the entrant and/or driver.

Yelling, shouting, physical altercations, bullying, and intimidation either directly at an event or offsite on any social media platforms are considered violations of this regulation

Violation of this regulation can result in penalties including loss of Series points, driving privilege suspension, monetary fine, exclusion from a track session and/or the event and/or the RMC Ontario Championship series.

6. Event and Championship Awards

Trophies – Each final will award the top 3 finishers in each RMC Ontario class and will receive podium trophies.

Rotax – At the conclusion of the championship, two (2) invitations to race at the Rotax MAX Challenge Grand Finals will be awarded in the following Rotax classes to the eligible drivers: MAX Senior and MAX Junior. Prizes will be awarded in these classes to the eligible driver scoring the most points including 1

drop in the combined results of the RMC Ontario Championship. Drivers will count the best 4 out of 5 points finishes.

7. Points Chart

Points for the season championship will be scored based on the official results of Pre-Final, and the Final for each race using the charts below. All results will count in the points standings.

Pre-Final Points

Pos	Pts	Pos	Pts
1	50	6	25
2	45	7	20
3	40	8	15
4	35	9	10
5	30	10	5

Final Race Points

Pos	Pts	Pos	Pts	Pos	Pts	Pos	Pts
1	200	11	102	21	50	31	28
2	180	12	96	22	46	32	27
3	170	13	90	23	42	33	26
4	160	14	84	24	40	34	25
5	150	15	78	25	38	35	24
6	142	16	72	26	36	36	23
7	134	17	66	27	34	37	22
8	126	18	62	28	32	38	21
9	118	19	58	29	30	39	20
10	110	20	54	30	29	40	19

Round 4 – Motomaster Canadian Karting Championships - Double Points

In round 4 the “Motomaster Canadian Karting Championship” the point structure is doubled from standard points structure.

PRE- FINAL Double Points

Pos	Pts	Pos	Pts
1	100	6	50
2	90	7	40
3	80	8	30
4	70	9	20
5	60	10	10

FINAL Double Points

Pos	Pts	Pos	Pts	Pos	Pts	Pos	Pts
1	400	11	204	21	100	31	56
2	360	12	192	22	92	32	54
3	340	13	180	23	84	33	52
4	320	14	168	24	80	34	50
5	300	15	156	25	76	35	48
6	284	16	144	26	72	36	46
7	268	17	132	27	68	37	44
8	252	18	124	28	64	38	42
9	236	19	116	29	60	39	40
10	220	20	108	30	58	40	38

8. Event Officials

Race Director	David Campbell	Assistant race Director	Russel Fox (Round 2&3)
Deputy Race Director:	Ryan Kilpatrick	Timing & Scoring:	Jen McIntosh
Starter:	Jordan West	Assistant Timing & Scoring:	Ty Cameron
Lead Tech Inspector:	Paul Hunter	Tech Inspector:	Joel McInstosh
Assistant Tech Inspector:	Mark Barnes	Grid Marshal	Cole Cameron

9. Regulations and Precedence of Regulations

The event will be run in accordance with:

GDS Canadian Karting Regulations - Book 1 Sporting Regulations, Book 2 Technical Regulations, Penalty Guidelines, Control Forms, Kart Racing Helmets and Front Fairing Drop-Down available at <https://www.asncanada.ca/karting>

2024 Rotax Max Challenge Canada Regulations available at <https://maxchallenge.ca>

The Regulations shall be as follows (in order of precedence):

- a) 2024 GDS Canadian Karting Regulations
- b) GDS Canadian Karting Regulations Bulletins
- c) 2024 Rotax Max Challenge Canada
- d) These Supplementary Regulations
- e) Official RMC Ontario Bulletins
- f) Instructions from Officials and on-site Bulletins

Any claim of lack of knowledge of the Regulations will not be entertained.

10. Amendment to Regulations

When an event official schedule has started, amendments involving the Regulations and the event schedule can only be made by the Series Chief Steward.

RMC Ontario Championship - Class Structure All Events

CLASS	WEIGHT	AGE	ENGINE	DRY TIRES	NATIONAL LICENCE
125 Mini MAX	260 lbs	8 - 13	FR125	MOJO 4.50/4.50 D5	B
125 Junior MAX	320 lbs	12 - 15	FR125	MOJO 4.50/7.10 D5	B
125 Senior MAX	364 lbs	15+	FR125	MOJO 4.50/7.10 D5	A

RMC Ontario will honor approved licenses from recognized ASN's.

125 Mini MAX Gear Ratio

For all RMC Ontario races Mini MAX will utilize a fixed gear ratio of 13T front Pinion and 73T Rear Sprocket – 13T/73T

All RMC Ontario Classes

- Stainless Steel Chassis Protectors are legal for use.
- Carbon Fiber Sprocket Protectors are legal for use.

RMC Ontario – CLASSES

RMC Ontario Reserves the right to include other categories to be run during RMC Ontario event.
RMC Ontario Supplementary Regulations

11. Wet Tires

- 125 Mirco/Mini - Mojo W5 - 4.50 / 4.50
- 125 Junior Max – Mojo W5 – 4.50 / 6.00
- 125 Senior Max – Mojo W5 – 4.50 / 6.00

12. Race Tires

Drivers must purchase one set of tires from the designated tire distributor on site at each venue. That one set of tires must be used for all official sessions for the entire race event. For Rounds 2 (Constructors Cup - Race 2 & 3), drivers may elect to run new tires for both race days.

Wet Tires:

Participants may acquire the specified wet tires from their own sources. Wet tires must be marked before the first use according to the event schedule.

The quantity of WET tires may be adjusted in an event bulletin depending on weather and track conditions. A time will be announced for the marking of rain tires or when used.

13. Fuel Specification:

Fuel used by the participants must comply with the Canadian Karting Regulations.

- 91 Octane Esso Supreme Spec fuel – Located on site and purchased from Canadian Mini Indy

14. Oil Specification

- All Rotax classes will use XPS KART TEC fully synthetic 2-stroke oil as the spec oil.

15. Eligible Entries and License Requirements

a) Residents of Canada

Canadian residents require an ASN National License and must be a member in good standing of an ASN affiliated Canadian kart club. They may enter any RMC Ontario Class provided they possess the appropriate National Grade license, their kart meets the appropriate technical requirements, and the driver meets the entry qualifications for their particular class.

b) Residents of the USA

Residents of the USA may enter any Class. Residents of the USA must possess a current and valid license/membership issued by a recognized USA karting organization. Their kart must meet the RMC Ontario Sporting and Technical Regulations.

c) Foreign Drivers

Foreign drivers are non-Canadian and non-USA drivers and must possess a current and valid Kart Racing License recognized by the ASN of their home country. In addition, the driver must present a Letter of Permission issued by the ASN of their home country authorizing them to compete.

16. Competition Numbers

All karts must have a unique number of three digits made up of numerals, The first digit in each three-digit number must correspond to the table below. No letters will be allowed. Numbers reserved with a National License takes precedence if two competitors have the same number.

Numbers	Class
101-199	125 Micro/Mini MAX
201-299	125 Junior MAX
301-399	125 Senior MAX

17. Event Schedule

The event schedule will be posted online and available at the track before each event at <https://rmcontario.com>

On the Fridays prior to the events there will be an optional test day organized by the facility. Please contact the track for information.

18. Additional or Team Paddock Spaces

Contact hosting facility to make arrangements.

19. Restricted Areas

The racetrack infield, the perimeter of the track, the Pit Lane, Pre-Grid, Grid, Scale Area and Technical Inspection areas are restricted areas.

Access to the Grid and Pit Lane is available only to participants when their class is running. One crewmember with a Mechanic's Pass is allowed on the Grid with each entry.

A Hot Pit will not be used during practice, qualification sessions or races.

Holders of Passes including team members and guests are entitled free access to the paddock and spectator areas only.

20. Number of Karts on the Racetrack

GDS Canadian Karting Regulations Book 1, Regulation 9.3.

A maximum of 36 karts will be allowed to start in a Final at all races. The Race Steward may alter the maximum number at all events.

21. Eligibility to Race in a Pre-Final and Final Race

All entries must participate in qualifying for their class. A driver who has not competed in Qualifying will start the Pre-Final in the rear.

All entries must participate in the Pre-Final for their class. A driver who has not competed in the Pre-Final may be allowed to start the Final at the rear with permission from the race director.

The finishing positions in the Pre-Final will determine the starting grid for the Final.

The finishing positions in the Final will be used to determine daily awards.

22. Qualifying Procedures

GDS Canadian Karting Regulations Book 1, Regulation 10.3. Qualifying for a Race.

For qualifying sessions, drivers may be split into groups depending on the size of the class. Drivers are required to be ready on the grid before their designated group session.

A driver may enter the track any time during the session only when allowed on track by the grid marshal.

Sessions will be timed as per the event schedule.

If a driver stops for any reason during a qualifying session the driver must move the kart to a safe area. They will be allowed to attempt to try and start again with or without assistance from race officials. A driver may not receive assistance from anyone other than an official of the event. If an official or marshal orders the driver to stop the driver must comply immediately.

23. Transponders

Each kart must be equipped with a transponder mounting bracket. The transponder must be installed according to AMB/MyLaps instructions on the back of the seat.

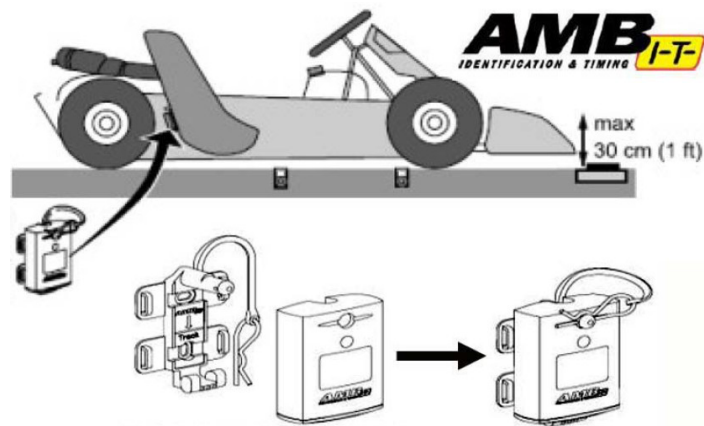

Event organizers will not have transponders for rent. Transponders may be rented from a third party. It is recommended that competitors purchase their own transponder.

Neither the Organizer nor the Officials are responsible for any transponder failure during the event.

Drivers must register their transponder number, either their own or one that is assigned, on the entry form or at the latest the time of the onsite event registration.

24. Marking of Engine and Tires

Engines and tires will be marked either manually or electronically, before or after qualification sessions. It is the driver's responsibility to be sure that their engine and tires are marked before leaving the area where the engine and/or tires are marked. Race tires must be declared on the Self-Declaration Technical Inspection form.

25. Re-starting Karts

GDS Canadian Karting Regulations Book 1, Regulations 11.1. Re-starting Karts.

26. Race Starts

For all classes except Shifter GDS Canadian Karting Regulations Book 1, Regulation 10.6 The Rolling Start

Procedure.

27. Procedure at the End of a Qualifying Session or Race

GDS Canadian Karting Regulations Book 1, Regulation 11.8. Procedure at the End of a Qualifying Session or Race.

28. Procedure at the End of Finals

GDS Canadian Karting Regulations Book 2, Regulation 6. POST-RACE TECHNICAL INSPECTION.

The top five (5) finishers in each Final race in each class will proceed to the Parc Fermé and remain there until released by Technical Officials.

29. Photography, Audio and Video Recording in Technical Inspection Areas

Taking photographs, recording audio or video is not permitted in technical inspection areas other than by Race Officials.

30. Official Notice Board

The Official Notice Board location will be designated at each event. Results will be posted on the sites information board.

31. Podium Ceremony

Prize and trophy winners must be present at the podium ceremony wearing their racing suits, closed and zipped. If a driver cannot attend the podium ceremony for a good reason, they must inform the Steward before the ceremony. Failure to respect this procedure exposes the competitor to penalty. Podium presentations will take place at the conclusion of each race day.